

Porovnanie výkonov hybridov Twineco® R717 kontajner

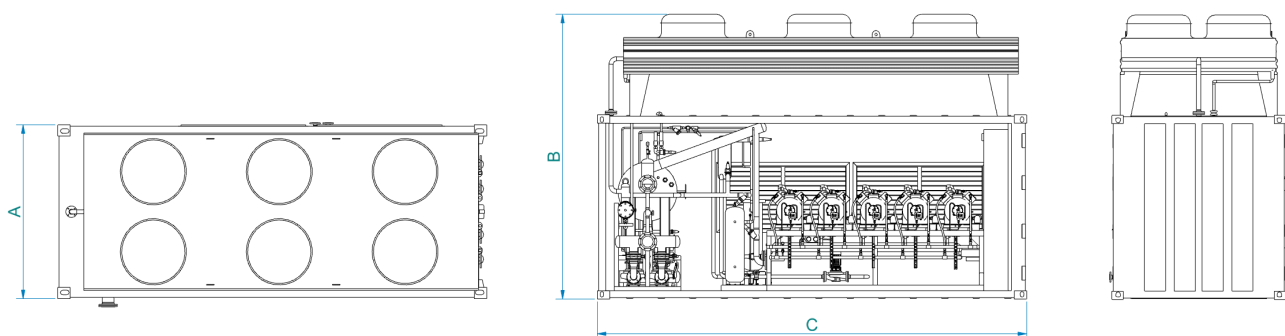
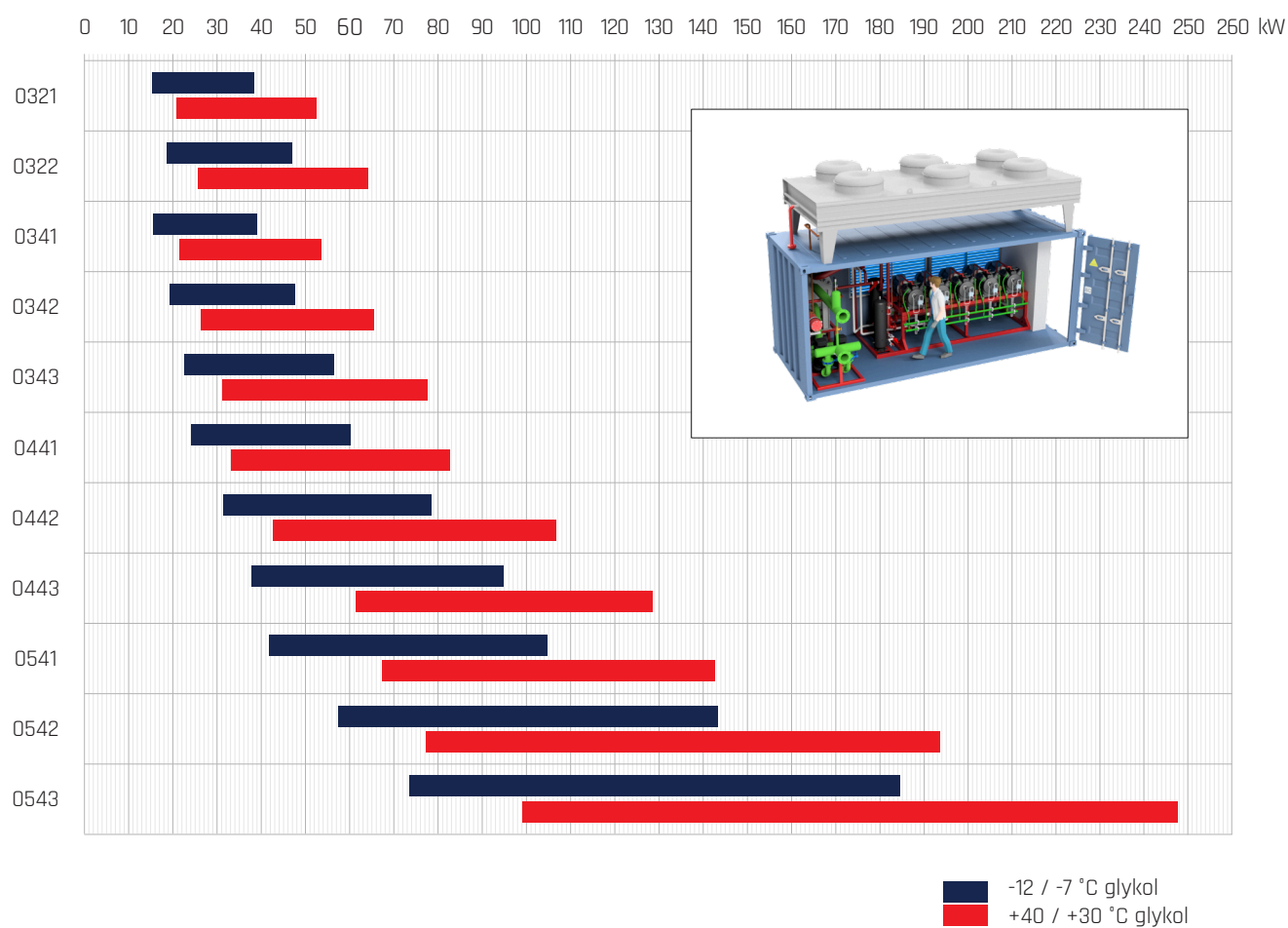

Hybridy Twineco® R717 kontajner

| Kontajner | Rozmery (mm) | | | Nosnosť (kg) |
|-------------|--------------|--------------|---------------|---------------|
| | Šírka A | Výška B | Dĺžka C | |
| 1D | 2 438 | 2 438 | 3 050 | 10 160 |
| 1CC | 2 438 | 2 591 | 6 100 | 24 000 |
| 1AAA | 2 438 | 2 896 | 12 200 | 30 480 |