

# SCREW REFRIGERATION UNITS

✓ wide application especially for industry, food industry  
- shock freezing, cooling tunnels, cold storage  
and freezer warehouses

✓ large capacity cooling and freezing

## Performance Comparison for Twineco® Screw Refrigeration Units

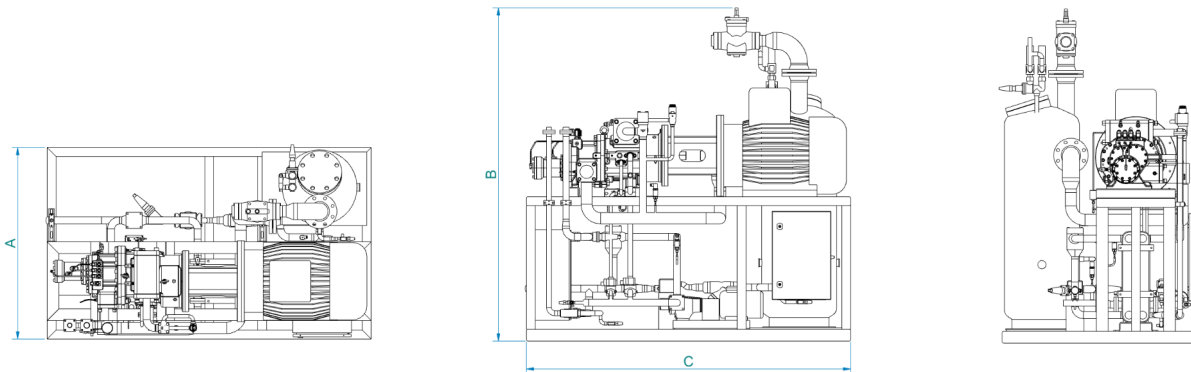
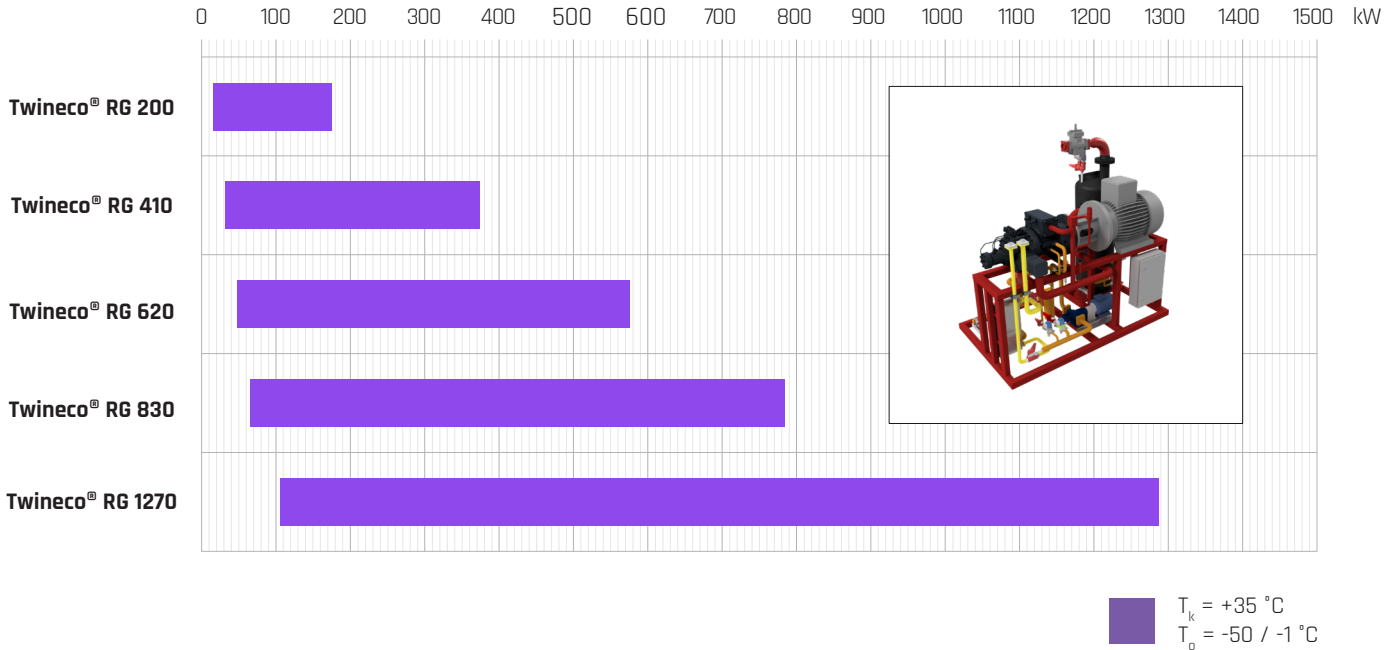

### Screw Refrigeration Units

Unit	Dimensions (mm)			Weight [kg]
	Width A	Height B	Length C	
<b>RG 200</b>	<b>900</b>	<b>1 800</b>	<b>2 200</b>	<b>1 100</b>
<b>RG 410</b>	<b>1 300</b>	<b>2 400</b>	<b>2 200</b>	<b>1 600</b>
<b>RG 620</b>	<b>1 300</b>	<b>2 400</b>	<b>2 500</b>	<b>2 500</b>
<b>RG 830</b>	<b>1 700</b>	<b>2 400</b>	<b>3 000</b>	<b>3 800</b>
<b>RG 1270</b>	<b>1 700</b>	<b>2 600</b>	<b>3 200</b>	<b>4 500</b>