

# CHILLERS - COOLERS

✓ plug & play liquid cooling technology with wide applications for cooling and freezing

✓ various uses for food production, industrial production processes, retail warehouses, commercial premises, etc.

## Performance Comparison for Twineco® Chillers R723

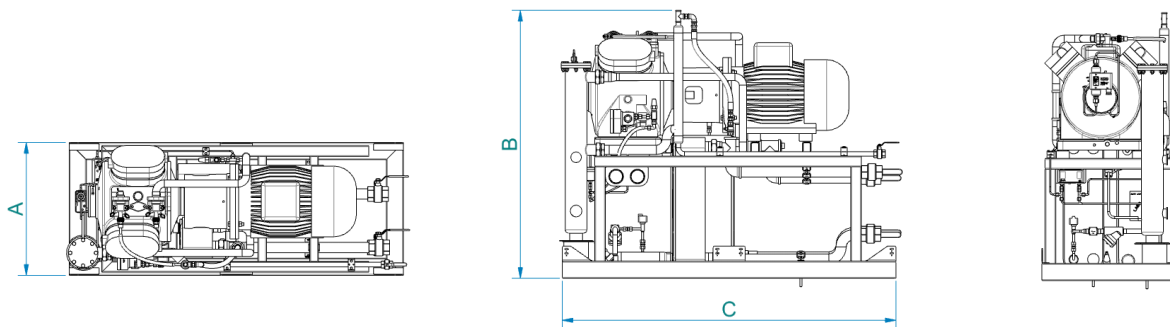
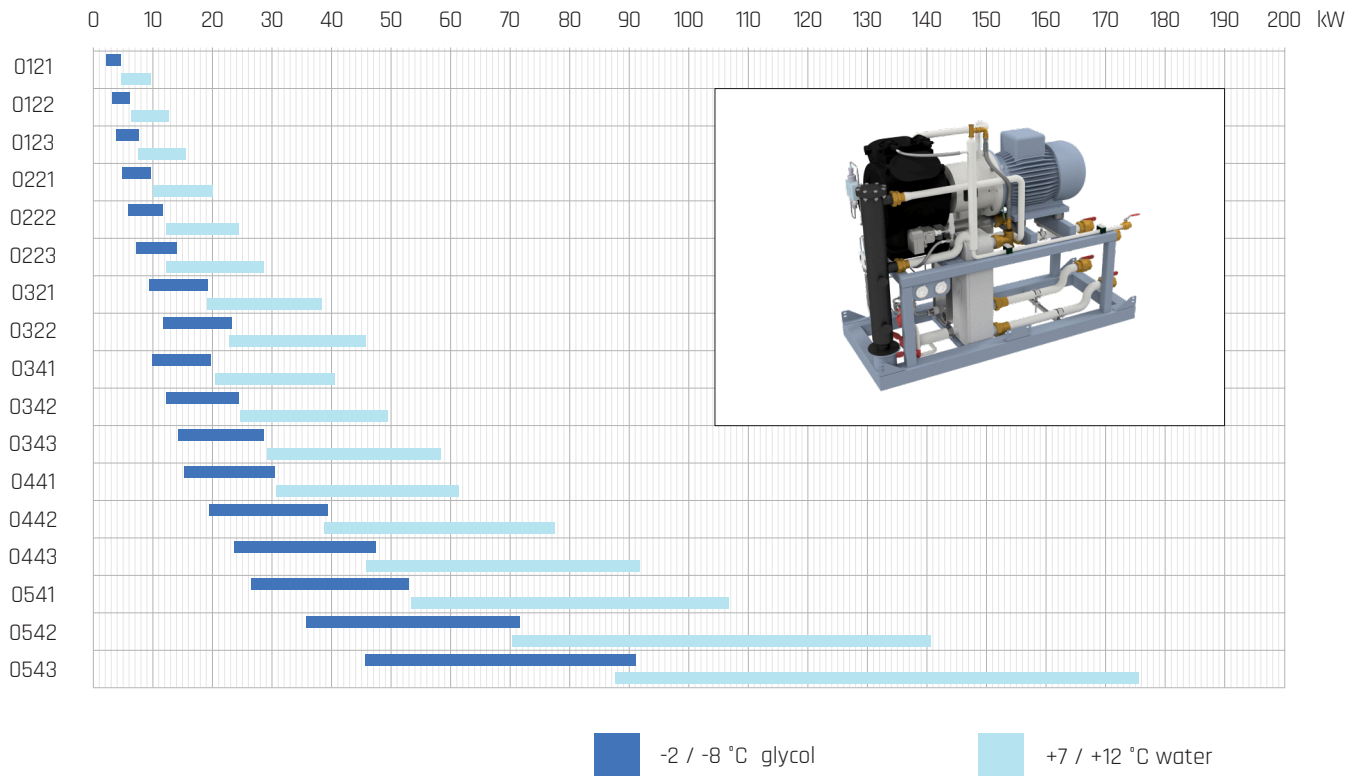

Twineco® Chillers R723					
Compressor	Number of compressors	Dimensions (mm)			Weight [kg]
		Width A	Height B	Length C	
0121 - 0123 0221 - 0223	1	520	1150	1110	280
0321 - 0322 0341 - 0343	1	570	1150	1285	420
0441 - 0443 0541 - 0543	1	620	1300	1560	620